

The Inaugural Cardboard Boat Race

INTRODUCTION, BOAT BUILDING & RULES



United Way of Bartow County's
Official 2020 Campaign Kick-Off
FRIDAY, AUG. 29, 2020

@Pine Acres Retreat
3963 Bartow Carver rd
Acworth, GA



INTRODUCTION

(CONTINUED ON NEXT PAGE)



The Inaugural Cardboard Boat Race is the official kick-off of United Way of Bartow County's annual fundraising campaign. This event boosts awareness, gets people excited, raises funds to help strengthen our community, celebrates the spirit of working together and helps increase workplace campaigns so that we can better advance the common good.

Taking part in the Inaugural Cardboard Boat Race is a great team building activity for your business. Your employees get to design, name, build and sail their own boat. On Race Day their coworkers, friends, and family are encouraged to join in the fun and come cheer them on. There are a number of workplace benefits:

- Facilitates better communication
- Promotes creativity
- Deepens relationships
- Increases morale
- Improves problem-solving skills
- Celebrates giving

Boats are made entirely of cardboard and duct tape and are powered by two (or more) rowers. They will race in heats around the cove at the Pine Acres Retreat off Allatoona Lake. Boats compete in individual heats for honor, glory and some really big trophies.

As a part of our TIKI team you will:

- Have a boatload of fun
- Compete in an amazing event
- Receive TIKI Bucks for use at the Food Truck Smorgasbord pre-event (\$50 value) and 2 free t-shirts for your team (with the option to buy additional shirts)
- Get 5 pieces of 4x8 foot cardboard (with the chance to purchase additional pieces)
- Have a safe racing environment on race day
- Help United Way raise bountiful TIKI bucks to uplift our community!

INTRODUCTION



COMMITMENT

Crews that wish to participate in the United Way of Bartow County's Inaugural Cardboard Boat Race commit to the following:

- Construct a boat out of cardboard and duct tape
- All boats are human powered (oars and paddles are acceptable as propulsion tools; you provide the oars/paddles; 2 or more people)
- Participate in the entire event which includes:
 - Bringing completed boat to the wharf on Friday, August 29 by 5:00 p.m. & attending the orientation from 5:00-6:00 p.m.
 - Securing your boat for over night on the cove (we will provide one roll of visqueen but recommend additional tarps/cover)
 - Attend the race on Saturday by checking in by 11:30 a.m. (you're welcome to come early! — food trucks and fun begin at 11:00)
 - Stay for brief awards ceremony after the race
 - Dispose of boat in provided dumpster or remove from property after the race

IMPORTANT DATES

August 2, 2020

Last day for boats to register. All boats must have submitted their final Name of Boat.

August 28 -Boat Drop-Off & Crew Orientation

Boats must be brought to the United Way cove by 5:00 p.m. From 5:00-6:00 p.m. there will be a Boat Crew Orientation. All boat rowers must be present. During this time, we will each collect team member's signed waivers and give out t-shirts. At the end of the meeting, boat crews will cover/protect their boat for overnight.

August 29 - RACE DAY!

Each boat entry will receive complimentary TIKI Bucks that can be used at the Food Truck Smorgasbord prior to and during the race (\$5 value for each TIKI buck) there will be no change given from TIKI bucks. From 11:00 a.m. through the race, guests will have the opportunity to sample a variety of foods from the best food trucks in our area, check out the boat displays in the wharf and "vote" for their favorite boat via cash and online donation. This is a great opportunity for boat builders to solicit donations for the People's Choice Award.

Boat crews should arrive by 11:30 a.m. at the latest. At this time the Guest Judges will pick their favorite boats. Teams are encouraged to come earlier if they have a staging area they wish to set up in the wharf. The boats hit the water at 3:00 p.m. The awards ceremony immediately follows the final race.

RACE COMPETITION

Heats will be drawn at random. The winner of each heat will move on to compete for first place in the final Championship Race heat. Boats will enter the water for the final heat based on how fast they completed their first heat, fastest to slowest.



AWARDS

- Place Trophies** will be awarded to all boats in the final heat. A cardboard boat must complete length of the course to qualify as a “finisher.” Swimming crewmembers pushing a boat (or some portion of it) through the course is not considered racing. The boat (or some portion of it) must be maneuvered and propelled by paddling crewmembers.
- Cardboard Crusaders Race:** any boat that is still sea worthy and not participating in the final heat is allowed to enter in the Cardboard Crusaders Race. This race is a one lap race with the winner receiving a special one-of-a-kind cardboard trophy from Welch Packaging.
- Race Medals** - Given to all registered participants including crew members and boat builders.

Special Trophies will be awarded for the following:

- Best in Race Award** (1st place) - First boat to cross the finish line in the final heat. Best in Race receives a traveling trophy for one year and will have that trophy replaced at the end of the year with a permanent one they can keep. All other boats in the final heat will also be awarded.
- Judges’ Choice Awards** - Awarded by the judges based on creativity, showmanship and team spirit. Costumes, props, and entourages are highly encouraged!
- People’s Choice Awards** - People’s Choice Awards are given to honor organizations that go above and beyond in their support for United Way. The money raised during our Great Cardboard Boat Race is used to help working families sail toward success. There are two distinct People’s Choice Awards:
- People’s Choice - Largest Treasure Chest** - presented to the company that raises the most money for United Way
 - People’s Choice - Most Mates** - presented to the company that has the most individual donors
- “Votes”/donations are given in advance of and on race day. Donations can be made online, by text message, by check at any time or by cash on Race Day. Previous winners of this award have done considerable fundraising prior to the day of the event.
- LIVE UNITED Award** - United Way staff awards this to the team who most embodies the LIVE UNITED spirit (hint: including UW logos, branding, etc. on your boat will help your chances)
- Cardboard Crusader Trophy sponsored by Welch Packaging** goes to the team who wins the Cardboard Crusader heat (see above).
- The Wonder That Went Down Under Award** (Most Spectacular Sinking) - Awarded to the crew who, in the opinion of the staff, was the most spectacular in the way the ship and its crew went down.

The awards ceremony will be held after the final heat and all boats are out of the water.



- ⚙ **Every crew member MUST wear a PERSONAL FLOTATION DEVICE (PFD)** & proper footwear. Please provide your own PFDs
- ⚙ All crew members MUST sign a Participant Waiver/Hold Harmless Agreement. Nobody will be allowed in the water without a signed agreement
- ⚙ Boats must have a minimum of two crew members
- ⚙ All boats are human powered. Please provide your own oars or paddles
- ⚙ Crew members are to abstain from alcohol consumption until after they are finished racing
- ⚙ Swimming crew members pushing a boat (or some portion of it) through the course is not considered racing. The boat (or some portion of it) must be maneuvered and propelled by paddling crew members

CONSTRUCTION

(CONTINUED ON NEXT PAGE)



- ⚙ **The ENTIRE boat must be built of cardboard, duct tape, and one-part polyurethane.** (Any part of your boat that touches the water must be cardboard. This includes the hull, decking, keel, cowling, superstructure, oar locks, seating and rudder. Nuts, bolts, washers and staples are **NOT** allowed in hull construction. The cardboard may be as thick as you want, but may **not** be glued or attached to wood, plastic, fiberglass, etc.)
 - ⚙ Only exceptions are the oars/paddles & decorations
- ⚙ Do use cardboard boxes, “blocks”, carpet tubes
- ⚙ NO pre-treated cardboard allowed
- ⚙ NO Sono -Tubes, waxed or ‘treated’ cardboard
- ⚙ NO wood, plastic, Styrofoam, or fiberglass
- ⚙ NO caulking compounds, two-part/mixed adhesives, or rubberizing paints/sprays
- ⚙ NO wrapping in duct tape, plastic, shrink wrap, fiberglass or similar product
- ⚙ Duct tape may be used to reinforce seams (Gorilla or similar-style tape is also acceptable)
- ⚙ **Duct tape, masking tape, or adhesives such as ‘liquid nails’ CAN be used to connect cardboard to cardboard and CAN be used to reinforce all seams and stress points. It CANNOT be used to waterproof by wrapping an entire boat.**

CONSTRUCTION

(CONTINUED ON NEXT PAGE)



- ⚙ Waterproof the boat with varnish, paint, or polyurethane (or any one-part, paint-like substance). If you don't want your boat to sink, waterproof the entire boat with any paintable one-part substance like varnish or polyurethane inside and out
- ⚙ Decorations are encouraged! They cannot, however, effect the structural strength or buoyancy unless made of cardboard
- ⚙ Boats CANNOT tow anything behind them for the safety of other boats
- ⚙ The crew compartment CANNOT be enclosed so as to interfere with escape
- ⚙ Boats should weigh less than 200 lbs. This rule is for us (in case you need help out of the cove)
- ⚙ Boats should be less than 6 feet wide – Here more is not better (or faster!)
- ⚙ Care should be taken that construction does not include pointed objects and sharp edges that could injure anyone
- ⚙ Surfboard style designs are NOT allowed. Consider “staying dry” part of the challenge. Feet and all should be out of the water.
- ⚙ Raft style designs ARE allowed. (The distinguishing feature of a raft design as opposed to a surfboard style is the use of cardboard “logs” and other such accoutrements. Think Huck Finn.)

MATERIALS



PERMISSIBLE MATERIALS

- ⚙ **Corrugated Cardboard**
 - Appliance or grocery stores
- ⚙ **Cardboard “blocks”**
 - Furniture stores
- ⚙ **Cardboard Tubes**
 - Carpet/linoleum stores
- ⚙ **Fastening material**
 - Duct, masking, clear or similar tape
 - Liquid nails adhesive
- ⚙ **Latex Paint, Varnish**

NOT ALLOWED

- ⚙ **Wood, styrofoam**
- ⚙ **Wrapping boat with duct tape, plastic, etc.**
- ⚙ **Fiberglass**
- ⚙ **Sona -Tubes, coated cardboard**
- ⚙ **Silicon, wax, tar, rubberizing product**
- ⚙ **Caulking compounds**
- ⚙ **Metal**
- ⚙ **Staples, clamps, screws**

*If there is any doubt about the construction, the judges reserve the right to use a probe, such as an ice pick, to test and verify that only cardboard has been used. Failure to abide by any design, race rule or the direction of a race official shall be cause for disqualification. The Judges' decision is final. Please contact the United Way office at morehouse.brenda@gmail.com or at 770.386.1677 if you have any questions.

DESIGN



- ⚙ Consider the logistics of building and transporting the boat
 - Big enough to hold crew, small enough to transport and carry
 - Wider is better for stability, but still must be able to paddle and turn
 - **No** surfboard style designs are allowed
 - Rafts are allowed
 - Consider total weight of all materials when waterlogged
 - EVERYTHING must be removed from the pond
- ⚙ Boat decorations and crew costumes are encouraged - use your imagination; you may be rewarded with the Judges' Choice or LIVE UNITED Awards
 - This year's race features a TIKI theme!



DISPLACEMENT



How much will you sink? - Displacement

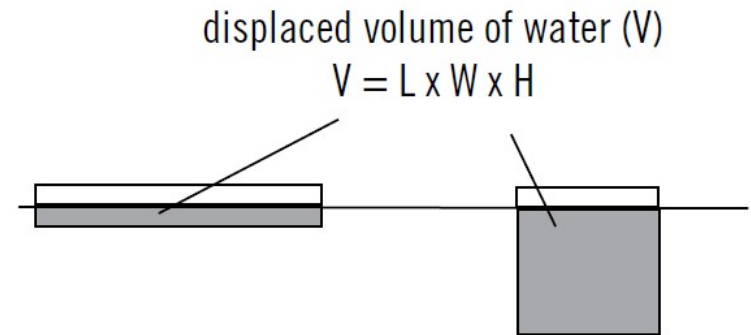
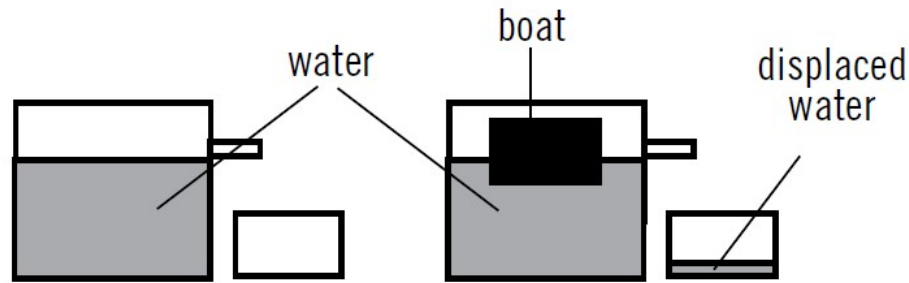

Weight of Water =
62.4 pounds/cubic-foot

$$\text{Water Displaced (ft}^3\text{)} = \frac{\text{Weight-of-boat-}\&\text{people-lbs}}{62.4\text{lbs/ft}^3\text{-H}_2\text{O}}$$

Depth (ft) boat sinks _____

EXAMPLE:

Box boat, 3ft x 6ft, 1 ft tall (high)
 Boat volume= 3' x 6' x 1' = 18 ft³
 Boat displacement= 18 ft³ x 62.4 lbs/ft³ = 1123.2 lbs
 Which equates to 93.6 lbs per inch of boat height

PHYSICS



Wider is steadier—Center of Buoyancy

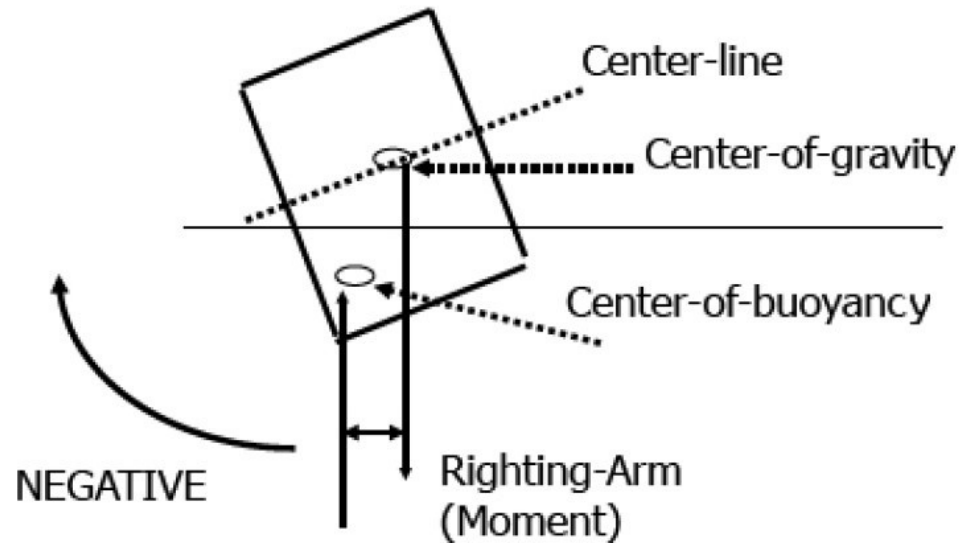
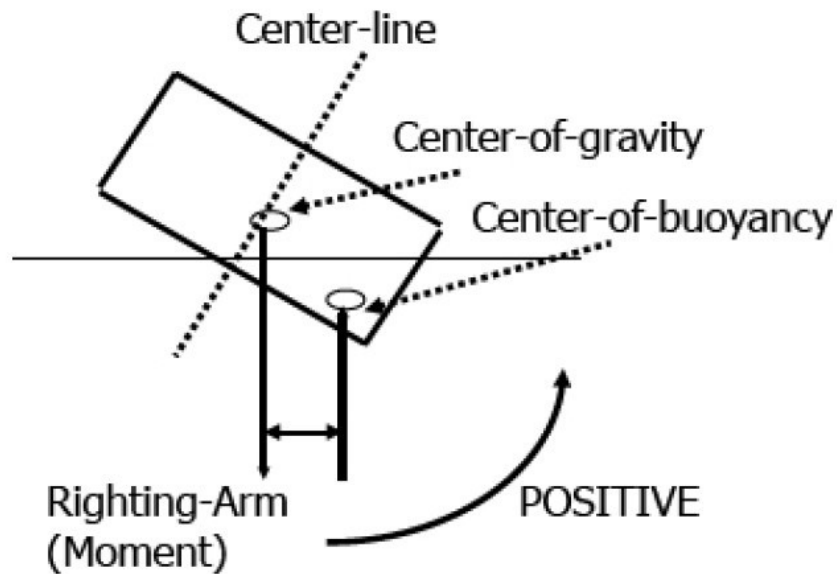

DESIGN



Basic boat styles



Simple
Box

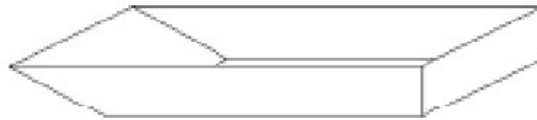

Slanted
Box



V-Shaped
Bow

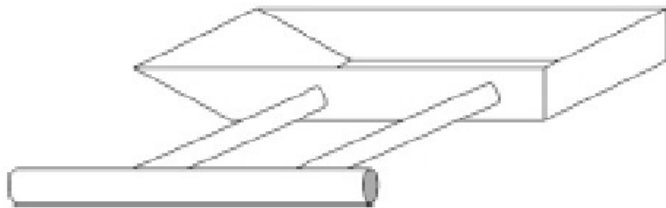

Outrigger
Design



Pontoon
Design

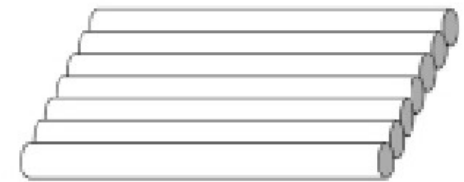

Raft
Design

DESIGN



Suggestions & Considerations:

- ⚙️ Set the Design Goal: Fun, Speed and Appearance
- ⚙️ Sketch out your design
 - build a scale model from manila paper:
 - estimate materials or plan how to use what you have
 - plan out what construction techniques will be used
- ⚙️ 1'x1'x3' box will float 187 lbs.
 - if it's big enough to hold you, it will float
- ⚙️ Flat bottom, sit-to-paddle & canoe styles have been the most popular and successful designs in the past
- ⚙️ Rudders help keep you straight but make turning difficult and adds complexity to your design
- ⚙️ Long boats go fast - but are harder to turn
- ⚙️ Short boats (<8') - are difficult to paddle straight
- ⚙️ Best Length: 8-12 feet
- ⚙️ Best Height: 18 inches
 - allows room to sit/kneel & still paddle over the edge
- ⚙️ Best Width:
 - 18"-30"(max) for 2 or more people in a row
 - Minimum 48" wide for 2 people side by side
- ⚙️ Kneeling is a "power" position but sitting is more comfortable

CONSTRUCTION



Construction Tips & Techniques:

- ⚙ Cover all edges and joints — cardboard acts like a siphon
- ⚙ Cardboard Tubes make great frames
 - Cut for joining & bending
- ⚙ Cardboard Hull
 - 1 or more layers, fasten & cover the seams
 - With 2 layers, overlap the seams & polyurethane in between
 - Decorate, paint & varnish
- ⚙ Reinforce the area where the crew will sit, kneel or stand
- ⚙ Carpenter's glue and liquid nails work well
 - hot-melt glues will melt in the heat and sun
- ⚙ Duct tape only non-painted surfaces (tubes or frame that will be covered)
 - Duct tape shrinks when painted
 - Duct tape should be covered with masking tape if you need to paint it
 - Clear tape melts when painted
 - Masking tape works well on glued edges & seams
 - Kraft paper with spray adhesive may also be used

CONSTRUCTION



Construction Tips & Techniques:

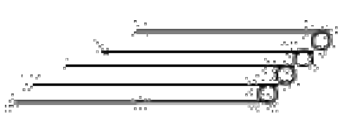

Solid Tube
Frame

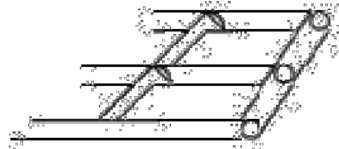

Center/Cross
Beam
Frame

FRAMES

FRAME ANGLES



V-Shaped Cuts

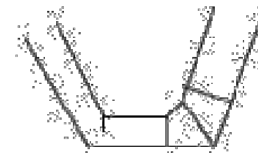

Multiple Cuts
for Sharper Angles

CONNECTING TUBES

Cardboard
Wrapper for Tubes
End-to-End



Cardboard
Wrapper for Tubes
At Right-Angles

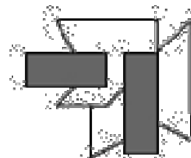

CONSTRUCTION



Construction Tips & Techniques:

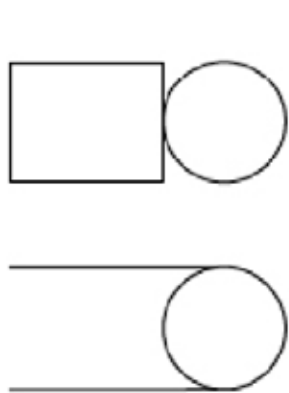

**TUBE CUTTING
TEMPLATE**

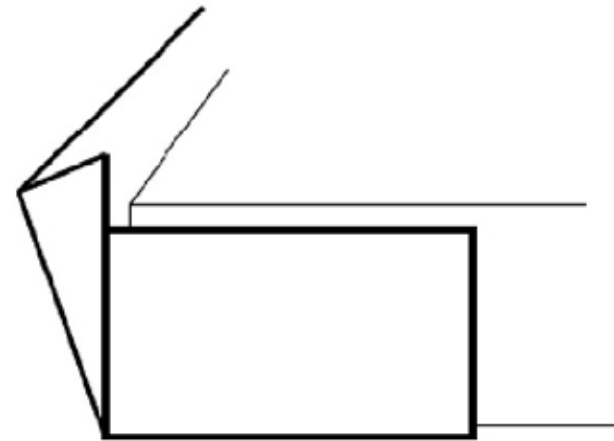

**FOLD & OVERLAP
CARDBOARD
AROUND CORNERS**

CONSTRUCTION

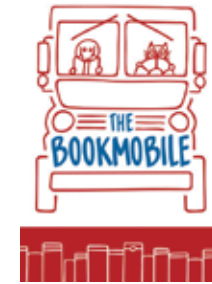

Construction Tips & Techniques:

Multiple cardboard layers
"glued" together on the sides
strengthen the hull

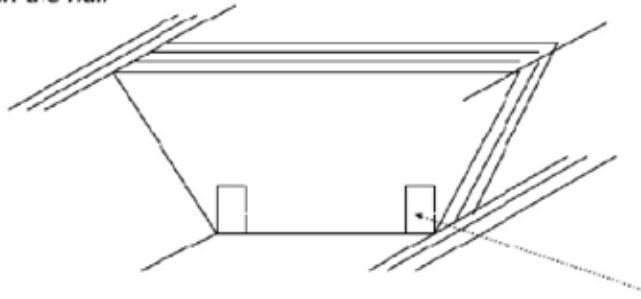

Multiple trapezoid-shaped pieces
"glued" together to form a
"support block"

A sheet of cardboard
could be folded &
"glued" together to form *tubes/beams*

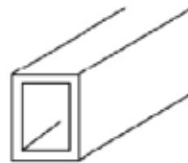

Crease/Score a line
for a nice

STRAIGHT
FOLD

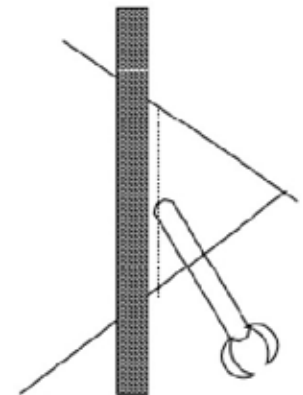



THE INAUGURAL CARDBOARD BOAT RACE

FRIDAY AUG. 29, 2020

Boats arrive August 28nd at Event
Location prior to 5 PM Crew
Orientation meeting



Questions? Contact Us:

United Way of Bartow County
P.O. Box 1264 Cartersville, Ga
30120

770.386.1677 or 678.438.2451

www.bartowliveunited.org

